

枠式ターンバックル寸法表

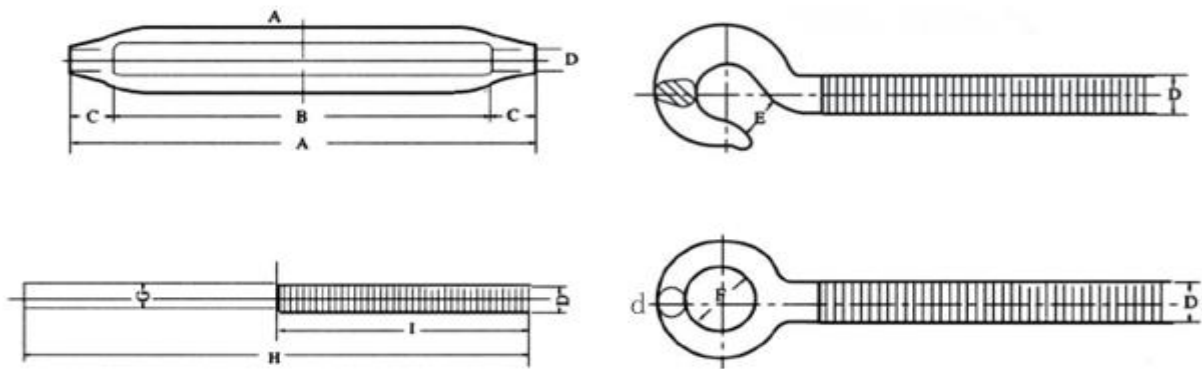

寸法公差：±5% 単位：mm 又はインチ（"）

| SIZE | A | B | C | d | D | E | F | G | H | I |
|------|-----|-----|----|------|------|----|----|-------|-----|-----|
| 6MM | 100 | 76 | 12 | 4.5 | 6 | 10 | 10 | | | |
| 8MM | 123 | 95 | 14 | 5.5 | 8 | 11 | 11 | | | |
| 9MM | 145 | 111 | 17 | 6.8 | 3/8" | 12 | 12 | 8.2 | 130 | 75 |
| 12MM | 200 | 164 | 18 | 9.5 | 1/2" | 15 | 19 | 10.72 | 150 | 95 |
| 16MM | 250 | 208 | 21 | 12.5 | 5/8" | 20 | 22 | 14.58 | 180 | 120 |
| 19MM | 300 | 250 | 25 | 13.0 | 3/4" | 22 | 30 | | | |
| 22MM | 325 | 273 | 26 | 13.5 | 7/8" | 26 | 33 | | | |
| 25MM | 350 | 294 | 28 | 17.5 | 1" | 28 | 35 | | | |

| SIZE | 使用荷重 両アイ | 破断荷重 両アイ | 重量 (Kg) | 使用荷重 両フック | 破断荷重 両フック | 重量 (Kg) |
|------|-------------|-------------|---------|--------------|--------------|---------|
| 6MM | 0.1T | 0.15T | 0.116 | 0.04T | 0.06T | 0.112 |
| 8MM | 0.2T | 0.3T | 0.22 | 0.08T | 0.12T | 0.215 |
| 9MM | 0.5T | 0.75 | 0.30 | 0.15T | 0.225T | 0.29 |
| 12MM | 1.8T | 2.7T | 0.58 | 0.3T | 0.45T | 0.57 |
| 16MM | 3T | 4.5T | 1.07 | 0.8T | 1.2T | 1.03 |
| 19MM | 4T | 6T | 1.77 | 1.2T | 1.8T | 1.77 |
| 22MM | 5T | 7.5T | 2.55 | 1.5T | 2.25T | 2.60 |
| 25MM | 5.5T | 8.25T | 3.79 | 1.8T | 2.7T | 3.72 |